

**Procedure for determining the specific activities of  
plutonium isotopes in fish  
by alpha spectrometry**

G- $\alpha$ -SPEKT-FISCH-01

Authors:

U. Rieth

G. Kanisch

A. Krüger

Federal coordinating office for fish and fishery products,  
crustacean, shell fish and aquatic plants

(Leitstelle für Fisch und Fischereierzeugnisse, Krustentiere,  
Schalentiere, Meereswasserpflanzen)

# Procedure for determining the specific activities of plutonium isotopes in fish by alpha spectrometry

## 1 Scope

The procedure described in the following is suitable for determining specific activities of the plutonium isotopes Pu-238 and Pu-(239+240) less than 1 mBq kg<sup>-1</sup> fresh mass (FM) in fish flesh and whole fish.

The procedure is used in the IMIS-routine programme and for radioecological research. It is very time consuming and requires experienced laboratory staff.

## 2 Sampling

For sampling it is referred to procedure G- $\gamma$ -SPEKT-FISCH-01.

## 3 Analysis

### 3.1 Principle of the procedure

The sample material is ashed according to procedure G- $\gamma$ -SPEKT-FISCH-01.

For determining specific activities of plutonium isotopes, a defined amount of Pu-242 tracer is added. If specific activities of additional radionuclides have to be analysed, corresponding tracers such as americium-243 (Am-243) as internal standard or strontium-85 (Sr-85) for the determination of the chemical yield of strontium are applied.

Afterwards, the ash is leached with nitric acid. The following liquid-liquid-extraction with tri-n-octylphosphineoxide (TOPO) dissolved in cyclohexane cleans the extract before uranium occurring in the sample is separated from plutonium via anion exchange.

The plutonium isotopes are electrochemically deposited on stainless steel plates and their activities are determined using a low-level alpha spectrometer.

### 3.2 Sample preparation

Samples are prepared according to procedure G- $\gamma$ -SPEKT-FISCH-01. The separation procedure described in the following is designed for processing a maximum of 100 g of ash; typically 50 g of fish ash are used. In addition, a blank sample is processed together with a sample set.

Before the analysis, all glassware is prepared according to Section 8.3.1 and the anion extraction column according to Section 8.3.2.

### 3.2.1 Sample preparation from fish ash

**3.2.1.1** The ash is processed in a muffle furnace at a maximum temperature of 500 °C for up to 48 hours. Directly after cooling down, the ash is determined. If not directly processed, the ash is stored in plastic bottles.

**3.2.1.2** The entire ash has to be dried again at 110°C for one hour before starting the analysis. Afterwards, it can be stored in a desiccator for a maximum of 12 hours.

**Note:**

Ashes are very hygroscopic. Without using a desiccator or at too long storing, the calculated ratio between fresh mass and ash mass cannot be used anymore if aliquots of the ash will be used for analysis. Therefore, the ash has to be dried again according to step 3.2.1.2.

**3.2.1.3** 50 g dry fish ash are weighed into a 600 ml beaker.

**3.2.1.4** A known activity of Pu-242 is added as internal standard; typically, around 0,05 Bq are used.

**Note:**

If the specific activity of Am-241 has to be determined from the same sample, a known activity of about 0,05 Bq Am-243 needs to be added.

**3.2.1.5** 300 ml nitric acid (8 mol·l<sup>-1</sup>) are added to the ash. The solution is heated on a hot plate and kept slightly boiling for 30 minutes while stirring.

### 3.2.2 Sample preparation after strontium separation

**3.2.2.1** If strontium-90 (Sr-90) and plutonium isotopes are to be determined from the same sample, the combined precipitates of the two acetate and the iron hydroxide precipitation from Section 3.3 of the procedure G-Sr-90-FISCH-02 are dissolved in 300 ml nitric acid (8 mol·l<sup>-1</sup>).

**3.2.2.2** The solution is heated on a hot plate and kept slightly boiling for 30 minutes while stirring.

Further steps of the procedure are described in Section 3.3 of this procedure.

## 3.3 Radiochemical separation

**3.3.1** While stirring, 5 ml sodium nitrite solution 1 (7,25 mol·l<sup>-1</sup>) are added to the hot solution.

**Note:**

The addition of sodium nitrite leads to a strong reaction with formation of nitrous fumes! Sodium nitrite is used for the chemical reduction of plutonium from oxidation state VI to oxidation state IV.

**3.3.2** After cooling down to room temperature, the solution is transferred to a centrifuge beaker. Afterwards it is centrifuged at about the 3160times the acceleration of gravity (3160 g) for 30 minutes.

**Note:**

If the centrifuge only allows the adaption of rotor speed in the unit of rotations per minute, the user manual has to be checked for the correct conversion.

**3.3.3** The supernatant is transferred into a 1000 ml beaker and is kept closed until further processing.

**3.3.4** The remaining precipitate is transferred to a 600 ml beaker with little nitric acid ( $8 \text{ mol}\cdot\text{l}^{-1}$ ).

**3.3.5** The volume of the solution is increased to 300 ml by addition of nitric acid ( $8 \text{ mol}\cdot\text{l}^{-1}$ ).

**Note:**

Caution: The formation of nitrous fumes is to be expected.

**3.3.6** The solution is heated on a hot plate while stirring until no nitrous fumes are released.

**3.3.7** Another 5 ml sodium nitrite solution 1 ( $7,25 \text{ mol}\cdot\text{l}^{-1}$ ) are added under stirring.

**3.3.8** After cooling down to room temperature, the solution is centrifuged according to step 3.3.2.

**3.3.9** The centrifugate of step 3.3.8 is combined with the centrifugate of step 3.3.3 and transferred to a 1000 ml separating funnel. The precipitate is discarded.

**Note:**

If the solution is processed directly, plutonium is still in the oxidation state IV. If not, the oxidation state IV must be readjusted with additional 5 ml sodium nitrite solution 1 ( $7,25 \text{ mol}\cdot\text{l}^{-1}$ ) before starting step 3.3.10.

**3.3.10** Plutonium is extracted from the nitric acid solution using 25 ml TOPO solution dissolved in cyclohexane ( $0,2 \text{ mol}\cdot\text{l}^{-1}$ ), which is added to the solution inside the separating funnel. Afterwards, the 1000 ml separating funnel is shaken for 15 minutes.

**3.3.11** The nitric acid phase (lower phase) is drained into a 1000 ml beaker, while the organic phase (upper phase) is transferred into a 250 ml separating funnel.

**3.3.12** The nitric acid phase and 25 ml TOPO solution dissolved in cyclohexane ( $0,2 \text{ mol}\cdot\text{l}^{-1}$ ) are transferred into the 1000 ml separating funnel used in step 3.3.11. The separating funnel is shaken for another 15 minutes.

**3.3.13** The nitric acid phase is drained into a 1000 ml beaker, kept closed and stored, if the specific Am-241 activity is also to be analysed according to procedure G- $\alpha$ -SPEKT-Fisch-02. Otherwise, the nitric acid phase is discarded.

**3.3.14** The organic phase of step 3.3.12 is transferred in the 250 ml separating funnel containing the organic phase from step 3.3.11. The combined organic phases are washed three times for five minutes after addition of 50 ml hydrochloric acid ( $3 \text{ mol}\cdot\text{l}^{-1}$ ), each. The washing solutions (lower phases) are discarded.

**3.3.15** For back-extraction of plutonium from the organic phase, 25 ml ascorbic acid ( $0,5 \text{ mol}\cdot\text{l}^{-1}$ ) in hydrochloric acid ( $1 \text{ mol}\cdot\text{l}^{-1}$ ) are added into the separating funnel. The separating funnel is shaken for 15 minutes.

**3.3.16** The ascorbic acid solution (lower phase) is transferred to a 250 ml beaker.

**3.3.17** Step 3.3.15 is repeated once.

**3.3.18** This ascorbic acid solution is combined with the solution of step Fehler! Verweisquelle konnte nicht gefunden werden. The organic phase is discarded.

**3.3.19** The ascorbic acid solution is shaken three times for 2 minutes after addition of 30 ml cyclohexane to the 250 ml separating funnel, each, to remove remaining TOPO from the aqueous phase. The organic phase (upper phase) is discarded after each shaking process.

**3.3.20** The ascorbic acid solution is transferred to the 250 ml beaker and evaporated to dryness on a sand bath at a temperature of  $60 \text{ }^{\circ}\text{C}$  to  $80 \text{ }^{\circ}\text{C}$  overnight.

**3.3.21** In order to ash the dark residue, the beaker is placed inside a muffle furnace and the following temperature program is started: Heat to  $200 \text{ }^{\circ}\text{C}$  within 2 hours, hold the temperature for 2 hours, raise the temperature to  $450 \text{ }^{\circ}\text{C}$  within 2 hours, hold this temperature for 60 hours and let the furnace cool down, afterwards.

**3.3.22** After ashing, the dark-grey residue is vaporized to dryness with 2 ml to 5 ml concentrated sulfuric acid ( $18 \text{ mol}\cdot\text{l}^{-1}$ ) and 5 ml to 10 ml concentrated nitric acid ( $14,4 \text{ mol}\cdot\text{l}^{-1}$ ). This process is repeated until the residue is considerably lighter coloured and the colour does not change any more.

**3.3.23** The residues is dissolved in 50 ml nitric acid ( $8 \text{ mol}\cdot\text{l}^{-1}$ ), and the solution is stirred on a hot plate at  $50 \text{ }^{\circ}\text{C}$  to  $70 \text{ }^{\circ}\text{C}$ . Afterwards, 0,25 ml sodium nitrite solution 2 ( $1,74 \text{ mol}\cdot\text{l}^{-1}$ ) are added and stirred for another 15 minutes.

**3.3.24** Subsequently, the beaker with the solution is placed within an ice-bath and cooled down to room temperature.

**3.3.25** The cooled solution is loaded on a prepared anion exchange column (see Section 8.3.2) and is perkolated through it at a velocity of 1 ml per minute to 2 ml per minute.

**3.3.26** After the solution has passed through, the column is rinsed with 100 ml of nitric acid ( $8 \text{ mol}\cdot\text{l}^{-1}$ ) followed by 150 ml hydrochloric acid ( $9 \text{ mol}\cdot\text{l}^{-1}$ ). The rinsing solutions are discarded.

**3.3.27** The plutonium adsorbed to the column material is eluted into a crystallizing dish using 10 ml of a mixed solution of hydrochloric acid ( $0,36 \text{ mol}\cdot\text{l}^{-1}$ ) and hydrofluoric acid ( $0,01 \text{ mol}\cdot\text{l}^{-1}$ ) at a velocity of 1 ml per minute.

**3.3.28** The eluate is mixed with 1 ml hydrochloric acid ( $12,1 \text{ mol}\cdot\text{l}^{-1}$ ) and evaporated to dryness at  $100 \text{ }^\circ\text{C}$  to  $120 \text{ }^\circ\text{C}$  on a sand bath.

**Note:**

There should be no visible residues, because plutonium is present in carrier-free form. However, if there are still residues visible, e. g. particles of anion exchange resin, the sample is repeatedly vaporized with 2 ml concentrated hydrochloric acid ( $12,1 \text{ mol}\cdot\text{l}^{-1}$ ) and 1 ml concentrated nitric acid ( $14,4 \text{ mol}\cdot\text{l}^{-1}$ ) until no residue is visible any more.

### **3.4 Preparation of the counting sources**

The electrodeposition apparatus and the stainless steel disks required for preparation of the counting sources are pre-treated according to Section 8.3.3.

**3.4.1** The dry residue in the crystallizing dish is dissolved in 0,4 ml hydrochloric acid ( $4 \text{ mol}\cdot\text{l}^{-1}$ ). The solution is transferred quantitatively into a prepared electrolysis vessel.

**3.4.2** Afterwards, the crystallizing dish is washed three times with 1 ml ammonium oxalate solution ( $0,32 \text{ mol}\cdot\text{l}^{-1}$ ) and once with 0,6 ml distilled water. The washing solutions are combined with the plutonium solution inside the electrolysis vessel.

**3.4.3** The plutonium is electrodeposited on the stainless steel disk over a duration of 4 hours at a constant current of 300 mA. The electrolysis vessel (see Section 8.2.2, Figure 1) is covered with a single bulb condenser to recover evaporated solution.

**3.4.4** Before the current is switched off, 1 ml ammonia solution ( $13,4 \text{ mol}\cdot\text{l}^{-1}$ ) is added and the electrodeposition is continued for 1 minute.

**3.4.5** The solution is discarded, the current is switched off, afterwards.

**3.4.6** The platinum electrode is removed and washed with distilled water. Afterwards, it is stored in nitric acid ( $14,4 \text{ mol}\cdot\text{l}^{-1}$ ).

**3.4.7** Finally, the electrolysis vessel containing the counting source is washed with slight ammonia-containing water (pH 8).

**3.4.8** The counting source is removed from the electrodeposition apparatus and thoroughly washed with slight ammonia-containing water (pH 8), first, followed by ethanol. Afterwards, the counting source is dried on a hot plate.

## **4 Measuring the activity**

### **4.1 General**

Basics of alpha spectrometry, such as calibration, measurement and evaluation of results are described in the General Chapter  $\alpha$ -SPEKT/GRUNDL of this Procedures Manual.

Considering the estimated low activities of plutonium isotopes in the IMIS routine mode, a distance of 1 mm between counting source and detector is recommended. The lines of Pu-239 and Pu-240 are very close in the pulse height spectrum and overlap, so only the sum of their activities is determined.

Due to the low estimated activities in the analysed samples, measurement durations of several days up to three weeks are required. The estimated specific activity of Pu-(239+240) is considerably less than 1 mBq·kg<sup>-1</sup> fresh mass. The activity ratio of Pu-238 and Pu-(239+240) range between 0,04 in fish from limnic waters and up to 0,20 in fish from the North Sea.

For the validation of the procedure, the analysis of certified standard reference material from marine environment, e. g. available from the International Atomic Energy Agency (IAEA), is recommended.

### **4.2 Calibration**

The energy calibration of the spectral region is carried out with sources whose nuclide composition is known.

To determine the detection efficiency of the detector, the counting yields are determined with calibration sources of known activity traceable to national primary standards. The counting yields are considered constant in the energy range of interest.

The background in the respective peak areas is detected by measurement of blank counting sources. These usually have impulse rates that differ only slightly from the background.

Further information can be found in the General Chapter RAD-CHEM/GRUNDL of this Procedures Manual.

### **4.3 Measurement**

The duration of measurement of the counting source is individually adapted to the expected activity and is usually one week for routine measurements. The counting source is measured at the same distance to the detector as the calibration source and blank counting source.

## 5 Calculation of the results

### 5.1 Equations

#### 5.1.1 Quantity

The calculation of the specific activities of Pu-(239+240) and Pu-238 with reference to the fresh mass (FM) is calculated according to Equation (1)

$$a_r = \varphi \cdot R_{n,r} \quad (1)$$

with the auxiliary Equations (2) to (6) for the calculation of the procedural calibration factor and the net count rates in the selected regions of interest in the pulse height spectrum:

$$\varphi = \frac{A_{Tr}}{m_a \cdot q_F} \cdot \frac{p_{\alpha,Tr}}{p_{\alpha,r}} \cdot \frac{f_1 \cdot f_3}{R_{n,Tr}} \quad (2)$$

$$R_{n,r} = R_{g,r} - R_{0,r} - R_{n,BL,r} \quad (3)$$

$$R_{n,Tr} = R_{g,Tr} - R_{0,Tr} - R_{n,BL,Tr} \quad (4)$$

$$R_{n,BL,r} = A_{BL,r} \cdot \varepsilon \cdot p_{\alpha,r} \quad (5)$$

$$R_{n,BL,Tr} = A_{BL,Tr} \cdot \varepsilon \cdot p_{\alpha,Tr} \quad (6)$$

In the Equations (1) to (6) are:

$a_r$  specific activity of plutonium isotope r, related to fresh mass, in Bq·kg<sup>-1</sup>;

$\varphi$  procedural calibration factor, in Bq·kg<sup>-1</sup>·s;

$R_{n,r}$  net count rate of the plutonium isotope r, in s<sup>-1</sup>;

$R_{g,r}$  gross count rate of the plutonium isotope r, in s<sup>-1</sup>;

$R_{0,r}$  background count rate in the alpha line of the plutonium isotope r, in s<sup>-1</sup>;

$R_{n,BL,r}$  net count rate in the alpha line of the plutonium isotope r in the blank counting source, in s<sup>-1</sup>;

$m_A$  mass of the ash used for analysis, in kg;

$q_F$  ratio of fresh mass to ash mass;

$f_1$  correction factor for the decay of the activity of the plutonium isotope r between sampling and beginning of measurement:

$$f_1 = e^{\lambda_r \cdot t_A}$$

with:  $\lambda_r$  decay constant of the plutonium isotope r, in s<sup>-1</sup>;

$t_A$  time period between sampling and beginning of measurement, in s;



$f_3$  correction factor for the decay of the activity of the Pu-242-tracer between calibration of the tracer solution and beginning of measurement:

$$f_3 = e^{-\lambda_{\text{Tr}} \cdot t_{\text{Tr}}}$$

with:  $\lambda_{\text{Tr}}$  decay constant of the Pu-242 tracer, in  $\text{s}^{-1}$ ;

$t_{\text{Tr}}$  time period between calibration of the tracer solution and beginning of the measurement, in s;

$t_m$  duration of measurement, in s;

$t_0$  duration of background measurement, in s;

$A_{\text{Tr}}$  added activity of the Pu-242 tracer referenced to the calibration of the tracer solution, in Bq;

$A_{\text{BL},r}$  activity of the plutonium isotope  $r$  in the blank counting source, in Bq;

$A_{\text{BL,Tr}}$  activity of the Pu-242-tracer in the blank counting source, in Bq;

$R_{n,\text{Tr}}$  net count rate of the Pu-242 tracer, in  $\text{s}^{-1}$ ;

$R_{g,\text{Tr}}$  gross count rate of the Pu-242 tracer, in  $\text{s}^{-1}$ ;

$R_{0,\text{Tr}}$  background count rate in the alpha line of the Pu-242 tracer, in  $\text{s}^{-1}$ ;

$R_{n,\text{BL,Tr}}$  net count rate in the alpha line of the Pu-242 tracer in the blank counting source, in  $\text{s}^{-1}$ ;

$p_{\alpha,r}$  sum of the emission intensities of the alpha lines of the plutonium isotope  $r$ ;

$p_{\alpha,\text{Tr}}$  sum of the emission intensities of the alpha lines of the Pu-242 tracer;

$\varepsilon$  detection efficiency of the measuring system, in  $\text{Bq}^{-1} \cdot \text{s}^{-1}$ .

The correction of radioactive decay during the measurement may be omitted in this case. In the present case, the correction factor  $f_3$  also equals 1 due to the long half time of the Pu-242 tracer. The sum of the emission intensities of alpha lines in the range of the plutonium isotope  $r$  is close to 1.

The chemical yield  $\eta$ , which is not explicitly occurring in equation (1), is calculated according to equation (7):

$$\eta = \frac{R_{n,\text{Tr}}}{\varepsilon \cdot A_{\text{Tr}}} \quad (7)$$

### 5.1.2 Standard uncertainty of the quantity

The standard uncertainty of the net count rate of the analyte in the blank counting source results from

$$u(R_{n,\text{BL},r}) = R_{n,\text{BL},r} \cdot \sqrt{u_{\text{rel}}^2(A_{\text{BL},r}) + u_{\text{rel}}^2(\varepsilon) + u_{\text{rel}}^2(p_{\alpha,r})} \quad (8)$$

The combined standard uncertainty of the analyte net count rate is calculated by Equation (9)

$$u^2(R_{n,r}) = \mu_0 \cdot R_{n,r}^2 + \mu_1 \cdot R_{n,r} + \mu_2 \quad (9)$$

with the auxiliary quantities:

$$\mu_0 = 0$$

$$\mu_1 = \frac{1}{t_m}$$

$$\mu_2 = R_{0,r} \cdot \left( \frac{1}{t_m} + \frac{1}{t_0} \right) + \frac{R_{n,BL,r}}{t_m} + u^2(R_{n,BL,r})$$

Using the auxiliary quantities, Equation (9) changes to:

$$u^2(R_{n,r}) = \frac{R_{n,r}}{t_m} + R_{0,r} \cdot \left( \frac{1}{t_m} + \frac{1}{t_0} \right) + \frac{R_{n,BL,r}}{t_m} + u^2(R_{n,BL,r}) \quad (10)$$

Correspondingly, the equation of standard uncertainty of the tracer's net count rate calculates to:

$$u^2(R_{n,Tr}) = \frac{R_{n,Tr}}{t_m} + R_{0,Tr} \cdot \left( \frac{1}{t_m} + \frac{1}{t_0} \right) + \frac{R_{n,BL,Tr}}{t_m} + u^2(R_{n,BL,Tr}) \quad (11)$$

The procedural calibration factor is presented as general product, so that its relative uncertainty according to Equation (12) is easier to be calculated from the relative uncertainties of its input quantities:

$$u_{rel}^2(\varphi) = u_{rel}^2(A_{Tr}) + u_{rel}^2(m_A) + u_{rel}^2(q_F) + u_{rel}^2(R_{n,Tr}) + u_{rel}^2(p_{\alpha,r}) + u_{rel}^2(p_{\alpha,Tr}) \quad (12)$$

The standard uncertainty of the specific activity  $u(a_r)$  calculates by:

$$u(a_r) = \sqrt{R_{n,r}^2 \cdot u^2(\varphi) + \varphi^2 \cdot u^2(R_{n,r})} = \sqrt{a_r^2 \cdot u_{rel}^2(\varphi) + \varphi^2 \cdot u^2(R_{n,r})} \quad (13)$$

## 5.2 Worked example

In the worked examples of the Sections 5.2 and 6.2, the interim results and the result are given with four significant digits. Deviations from the calculated values are possible when using another number of significant digits.

The following numeric quantity values are used for calculation of the specific activity of Pu-(239+240) in 2,3 kg fish flesh (FM):

$R_{g,Pu-(239+240)}$	=	$61,7284 \cdot 10^{-6} \text{ s}^{-1}$ ;	$u(R_{g,Pu-(239+240)})$	=	$5,833 \cdot 10^{-6} \text{ s}^{-1}$ ;
$R_{g,Pu-242}$	=	$13,618 \cdot 10^{-3} \text{ s}^{-1}$ ;	$u(R_{g,Pu-242})$	=	$86,635 \cdot 10^{-6} \text{ s}^{-1}$ ;
$R_{0,Pu-(239+240)}$	=	$3,0 \cdot 10^{-6} \text{ s}^{-1}$ ;	$u(R_{0,Pu-(239+240)})$	=	$1,225 \cdot 10^{-6} \text{ s}^{-1}$ ;
$R_{0,Pu-242}$	=	$2,0 \cdot 10^{-6} \text{ s}^{-1}$ ;	$u(R_{0,Pu-242})$	=	$1,0 \cdot 10^{-6} \text{ s}^{-1}$ ;
$A_{BL,Pu-(239+240)}$	=	$12,13 \cdot 10^{-6} \text{ Bq}$ ;	$u_{rel}(A_{BL,Pu-(239+240)})$	=	0,35499;
$A_{Pu-242}$	=	$56,375 \cdot 10^{-3} \text{ Bq}$ ;	$u_{rel}(A_{Pu-242})$	=	$5,6248 \cdot 10^{-3}$ ;
$A_{BL,Pu-242}$	=	$0,180 \cdot 10^{-3} \text{ Bq}$ ;	$u_{rel}(A_{BL,Pu-242})$	=	0,7222;
$p_{\alpha,Pu-(239+240)}$	=	1,00;	$u_{rel}(p_{\alpha,Pu-(239+240)})$	=	0,001;
$p_{\alpha,Pu-242}$	=	1,00;	$u_{rel}(p_{\alpha,Pu-242})$	=	0,001;
$q_F$	=	32,33;	$u_{rel}(q_F)$	=	0,02;
$\varepsilon$	=	$36,03 \text{ Bq}^{-3} \cdot \text{s}^{-1}$ ;	$u_{rel}(\varepsilon)$	=	$13,045 \cdot 10^{-3}$ ;
$m_A$	=	0,704 kg;	$u_{rel}(m_A)$	=	$2,841 \cdot 10^{-3}$ .

The standard uncertainties of the following quantities are neglectable:

$t_m$	=	$1,81440 \cdot 10^6 \text{ s}$ ;	$f_1$	=	1,0;
$t_0$	=	$2 \cdot 10^6 \text{ s}$ ;	$f_3$	=	1,0;
$t_A$	=	$45,88 \cdot 10^6 \text{ s}$ .			

The net count rates according to the Equations (3) to (6) can be calculated to:

$$R_{n,BL,Pu-(239+240)} = 12,13 \cdot 10^{-6} \cdot 0,3603 \cdot 1,00 \text{ s}^{-1} = 4,370 \cdot 10^{-6} \text{ s}^{-1}$$

$$R_{n,BL,Pu-242} = 0,180 \cdot 10^{-3} \cdot 0,3603 \cdot 1,00 \text{ s}^{-1} = 64,85 \cdot 10^{-6} \text{ s}^{-1}$$

$$R_{n,Pu-(239+240)} = (61,7284 - 3,0 - 4,370) \cdot 10^{-6} \text{ s}^{-1} = 54,36 \cdot 10^{-6} \text{ s}^{-1}$$

$$R_{n,Pu-242} = (13,618 \cdot 10^{-3} - 2,0 \cdot 10^{-6} - 64,85 \cdot 10^{-6}) \text{ s}^{-1} = 13,55 \cdot 10^{-3} \text{ s}^{-1}$$

The corresponding standard uncertainties are obtained by using the Equations (8) to (11):

$$\begin{aligned} u(R_{n,BL,Pu-(239+240)}) &= 4,370 \cdot 10^{-6} \cdot \sqrt{0,35499^2 + (13,045 \cdot 10^{-3})^2 + 0,001^2} \text{ s}^{-1} = \\ &= 1,552 \cdot 10^{-6} \text{ s}^{-1} \end{aligned}$$

$$\begin{aligned} u(R_{n,BL,Pu-242}) &= 64,85 \cdot 10^{-6} \cdot \sqrt{0,7222^2 + (13,045 \cdot 10^{-3})^2 + 0,001^2} \text{ s}^{-1} = \\ &= 46,84 \cdot 10^{-6} \text{ s}^{-1} \end{aligned}$$

$$u(R_{n,\text{Pu-(239+240)}}) = \sqrt{29,96 + 3,153 + 2,409 + (1,552)^2} \cdot 10^{-6} \text{ s}^{-1} = 6,159 \cdot 10^{-6} \text{ s}^{-1}$$

$$\text{with: } \frac{R_{n,\text{Pu-(239+240)}}}{t_m} = \frac{54,36 \cdot 10^{-6} \text{ s}^{-1}}{1,8144 \cdot 10^6 \text{ s}} = 29,96 \cdot 10^{-12} \text{ s}^{-2}$$

$$R_{0,\text{Pu-(239+240)}} \cdot \left( \frac{1}{t_m} + \frac{1}{t_0} \right) = 3,0 \cdot 10^{-6} \text{ s}^{-1} \cdot \left( \frac{1}{1,8144 \cdot 10^6 \text{ s}} + \frac{1}{2,0 \cdot 10^6 \text{ s}} \right) = \\ = 3,153 \cdot 10^{-12} \text{ s}^{-2}$$

$$\frac{R_{n,\text{BL,Pu-(239+240)}}}{t_m} = \frac{4,370 \cdot 10^{-6} \text{ s}^{-1}}{1,8144 \cdot 10^6 \text{ s}} = 2,409 \cdot 10^{-12} \text{ s}^{-2}$$

$$u(R_{n,\text{Pu-242}}) = \sqrt{7,468 \cdot 10^{-9} + 2,102 \cdot 10^{-12} + 35,74 \cdot 10^{-12} + (46,84 \cdot 10^{-6})^2} \text{ s}^{-1} = \\ = 98,49 \cdot 10^{-6} \text{ s}^{-1}$$

$$\text{with: } \frac{R_{n,\text{Pu-242}}}{t_m} = \frac{13,55 \cdot 10^{-3} \text{ s}^{-1}}{1,8144 \cdot 10^6 \text{ s}} = 7,468 \cdot 10^{-9} \text{ s}^{-2}$$

$$R_{0,\text{Pu-242}} \cdot \left( \frac{1}{t_m} + \frac{1}{t_0} \right) = 2,0 \cdot 10^{-6} \text{ s}^{-1} \cdot \left( \frac{1}{1,8144 \cdot 10^6 \text{ s}} + \frac{1}{2,0 \cdot 10^6 \text{ s}} \right) = \\ = 2,102 \cdot 10^{-12} \text{ s}^{-2}$$

$$\frac{R_{n,\text{BL,Pu-242}}}{t_m} = \frac{64,85 \cdot 10^{-6} \text{ s}^{-1}}{1,8144 \cdot 10^6 \text{ s}} = 35,74 \cdot 10^{-12} \text{ s}^{-2}$$

The procedural calibration factor defined in Equation (2) amounts to:

$$\varphi = \frac{56,375 \cdot 10^{-6}}{0,0704 \cdot 32,33} \cdot \frac{1,00}{1,00} \cdot \frac{1,0 \cdot 1,0}{13,55 \cdot 10^{-3}} \text{ Bq} \cdot \text{s} \cdot \text{kg}^{-1} = 1,828 \text{ Bq} \cdot \text{s} \cdot \text{kg}^{-1}$$

The specific activity in fish flesh relating to fresh mass according to Equation (1) is:

$$a_{\text{Pu-(239+240)}} = 1,828 \text{ Bq} \cdot \text{s} \cdot \text{kg}^{-1} \cdot 54,36 \cdot 10^{-6} \text{ s}^{-1} = 99,37 \cdot 10^{-6} \text{ Bq} \cdot \text{kg}^{-1}$$

The relative standard uncertainty of the procedural calibration factor is calculated according to Equation (12):

$$u_{\text{rel}}(\varphi) = \sqrt{5,6248^2 \cdot 10^{-6} + 2,841^2 \cdot 10^{-6} + 0,02^2 + \left(\frac{98,49 \cdot 10^{-6}}{13,55 \cdot 10^{-3}}\right)^2 + 0,001^2 + 0,001^2} =$$

$$= 22,24 \cdot 10^{-3}$$

The relative standard uncertainty of the specific activity is according to Equation (13):

$$u(a_{\text{Pu-(239+240)}}) = \sqrt{99,37^2 \cdot 10^{-12} \cdot 22,24^2 \cdot 10^{-6} + 1,828^2 \cdot 6,159^2 \cdot 10^{-12}} \text{ Bq} \cdot \text{kg}^{-1} =$$

$$= 11,47 \cdot 10^{-6} \text{ Bq} \cdot \text{kg}^{-1}$$

Therewith, the specific activity of Pu-(239+240) in fish flesh related to fresh mass results to:

$$a_{\text{Pu-(239+240)}} = (99,37 \pm 11,47) \cdot 10^{-6} \text{ Bq} \cdot \text{kg}^{-1} \text{ (FM)}$$

### 5.3 Consideration of the uncertainties

Uncertainty contributions arising from sampling are not taken into account in the framework of this Procedures Manual, as these can depend on many different and often not quantifiable factors.

The combined standard uncertainty includes besides the standard uncertainties of the counting statistics and also that of the radiochemical separation, the determination of the chemical yield and of the calibration. The activities of the plutonium isotopes are normally in the range of the decision threshold, so the proportion of the counting statistics is dominating. The combined standard uncertainty normally amounts between 10 % and 30 %.

## 6 Characteristic limits of the procedure

The calculation of the characteristic limits follows the standard ISO 11929 series [7].

An Excel spreadsheet (see Section 7.1) as well as a project file for the software Uncert-Radio (see Section 7.2) are available on the website of this Procedures Manual.

Further considerations concerning the characteristic limits are to be found in the General Chapters ERK/NACHWEISGR-ISO-01 and ERK/NACHWEISGR-ISO-02 of this Procedures Manual.

## 6.1 Equations

### 6.1.1 Decision threshold

The decision threshold  $a_r^*$  is calculated by use of the auxiliary quantity  $\mu_2$  as follows:

$$a_r^* = k_{1-\alpha} \cdot \varphi \cdot \sqrt{\mu_2} \quad (14)$$

$k_{1-\alpha}$  is the quantile of the normal distribution for the probability of the type I error  $\alpha$ .

### 6.1.2 Detection limit

The equation for calculation of the detection limit  $a_r^\#$  is

$$a_r^\# = \frac{a_r^* \cdot \psi}{\theta} \cdot \left[ 1 + \sqrt{1 - \frac{\theta}{\psi^2} \cdot \left( 1 - \frac{k_{1-\beta}^2}{k_{1-\alpha}^2} \right)} \right] \quad (15)$$

with the auxiliary quantities:

$$\theta = 1 - k_{1-\beta}^2 \cdot (u_{\text{rel}}^2(\varphi) + \mu_0), \quad (16)$$

$$\psi = 1 + \frac{k_{1-\beta}^2}{2 \cdot a_r^*} \cdot (\varphi \cdot \mu_1) \quad (17)$$

$k_{1-\beta}$  is the quantile of the normal distribution for the probability of the type II error  $\beta$ .

### 6.1.3 Limits of the coverage interval

The calculation of limits of the coverage interval is not required.

## 6.2 Worked examples

With the quantile  $k_{1-\alpha} = 3$  and the values of the quantities from Section 5.2 as well as the value of the auxiliary quantity  $\mu_2$  arising from Equation (9)

$$\mu_2 = 3,153 \cdot 10^{-12} \text{ s}^{-2} + 2,409 \cdot 10^{-12} \text{ s}^{-2} + (1,552 \cdot 10^{-6})^2 \text{ s}^{-2} = 7,971 \cdot 10^{-12} \text{ s}^{-2}$$

the decision threshold  $a_{\text{Pu-(239+240)}}^*$  is calculated to:

$$a_{\text{Pu-(239+240)}}^* = 3 \cdot 1,828 \cdot \sqrt{7,971 \cdot 10^{-12}} = 15,48 \cdot 10^{-6} \text{ Bq} \cdot \text{kg}^{-1}$$

With the quantile  $k_{1-\beta} = 1,645$  and the values of the auxiliary quantities from the Equations (16) and (17)

$$\theta = 1 - 1,645^2 \cdot [(22,24 \cdot 10^{-3})^2 + 0] = 0,9987$$

$$\psi = 1 + \frac{1,645^2}{2 \cdot 15,48 \cdot 10^{-6}} \cdot 1,828 \cdot \frac{1}{1,8144 \cdot 10^6} = 1,088$$

the detection limit of the specific Pu-(239+240)-activity  $a_{\text{Pu-(239+240)}}^{\#}$  calculates according to Equation (15) to:

$$\begin{aligned} a_{\text{Pu-(239+240)}}^{\#} &= \frac{15,48 \cdot 10^{-6} \cdot 1,088}{0,9987} \cdot \left[ 1 + \sqrt{1 - \frac{0,9987}{1,088^2} \cdot \left( 1 - \frac{1,645^2}{3^2} \right)} \right] \text{Bq} \cdot \text{kg}^{-1} = \\ &= 27,66 \cdot 10^{-6} \text{ Bq} \cdot \text{kg}^{-1} \end{aligned}$$

## 7 Software supported calculation

### 7.1 View of the Excel spreadsheet

Procedure for determining the specific activities of plutonium isotopes in fish by alpha spectrometry

G- $\alpha$ -SPEKT-FISCH-01

Version November 2015 / verified November 2020

Procedures manual for monitoring of radioactive substances in the environment and of external radiation (ISSN 1865-8725)

SAMPLE IDENTIFICATION:

17379, herring (whole fish)

ANALYTE: Pu-(239+240)

#Number of parameters p	16
k_alpha	3
k_beta	1,645
gamma	0,05

Create Excel variables!

User-Input:	Input of values
	Definition Excel variables
	Input of Excel formulae
Excel-VBA:	#Keywords
	Values from Vbasic

Data input:		variable names:		Uncertainty budget:			
#Values of parameters p	Unit	Excel variable	Input values	StdDev	partial derivatives	uncertainty budget:	budget in %
p 1	#Number of gross counts Ng	Ng	112,0	10,58300524	1,0074E-06	1,0661E-05	86,36086299
p 2	background count rate in the lines of Pu-(239+240)	R0	3,000000E-06	1,22470E-06	-1,82781471	2,2385E-06	3,807364547
p 3	gross count rate of the tracer Pu-242	RgTr	1,361800E-02	8,66350E-05	-0,00733194	6,352E-07	0,306566785
p 4	background count rate in the line of the tracer Pu-242	R0Tr	2,000000E-06	1,00000E-06	0,00733194	7,3319E-09	4,0845E-05
p 5	duration of measurement	tm	1,814400E+06		-6,2185E-11	0	0
p 6	Pu-(239+240) activity in the blank counting source	ABl	1,213000E-05	4,30620E-06	-0,65856164	2,8359E-06	6,110573086
p 7	activity of the tracer in the blank counting source	ABIT	1,800000E-04	1,30000E-04	0,0026417	3,4342E-07	0,089609585
p 8	activity concentration of the Pu-242 tracer solution	_CT1	0,225500000	1,13000E-03	0,0004406	4,9788E-07	0,188345417
p 9	added volumen of Pu-242 tracer solution	_VT1	0,250000000	6,60000E-04	0,00039743	2,623E-07	0,052275611
p 10	mass of the ash used for analysis	ma	0,070400000	2,00000E-04	-0,00141131	2,8226E-07	0,060534794
p 11	ratio of fresh mass to ash mass	qF	32,33000	6,46600E-01	-3,0732E-06	1,9871E-06	3,000201229
p 12	sum of the emission intensities of the Pu-242 tracer	PaT	1,000000000	1,00000E-03	9,9832E-05	9,9832E-08	0,007572483
p 13	sum of the emission intensities of the Pu-(239+240)	PaA	1,000000000	1,00000E-03	-0,00010734	1,0734E-07	0,008755086
p 14	detection efficiency	eps	0,360300000	4,70000E-03	-2,0852E-05	9,8003E-08	0,007297548
p 15	decay correction for Pu-(239+240)	_f1	1,000000000	0	9,9356E-05	0	0
p 16	decay correction for the Pu-242 tracer	_f3	1,000000000	0	9,9356E-05	0	0
(List can be continued here)							
<b>Model section</b>		<b>c = phix * Rn</b>					
<b>Auxiliary equations h</b>				(Formulae)			
h 1	#Gross count rate Rg	1/s	RgA	6,17284E-05			
h 2	count rate in the alpha lines of Pu-(239+240) in a blank counting source	1/s	RBL	4,37044E-06			
h 3	count rate in the alpha lines of the Pu-242 tracer in a blank counting source	1/s	RBLT	6,48540E-05			
h 4	net count rate of the tracer	1/s	RnT	0,013551146			
h 5	added activity of the Pu 242-tracer	Bq	Atr	0,056375			
h 6	chemical yield		eta	0,667152638			
(List can be continued here)							
	#Net count rate Rn	1/s	Rn	5,4358E-05			
	#Calibration factor, proc.dep.	Bq*s/kg	phix	1,82781470			
	#Value output quantity	Bq/kg	Result	9,93563E-05	2,76703E-05	←- output value modifiable by VBA	
	#Combined standard uncertainty	Bq/kg	uResult	1,14723E-05			
	#Decision threshold	Bq/kg		1,54829E-05			
	#Detection limit	Bq/kg		2,76703E-05			
further derived values							
	Auxiliary quantity Omega		Omega	1			
	Best estimate	Bq/kg	BestEst	9,93563E-05			
	Uncertainty best estimate	Bq/kg		1,14723E-05			
	Lower confidence limit	Bq/kg		7,6871E-05			
	Upper confidence limit	Bq/kg		0,000121842			

Calculate!

The corresponding Excel spreadsheet is available on the website of this Procedures Manual.



## 7.2 View of the UncertRadio result page

UR UncertRadio: Calculation of uncertainty budget and detection limits - G-alpha-SPEKT-FISCH-01\_V2015-11\_gp2020-11\_EN.txp

File Edit Options Help

Procedure Equations Values, Uncertainties Uncertainty budget Results Text Editor

**Final measurement result for a239 :**

Value output quantity:	9.93563E-05	Bq/kg FM
extendend (Std.-)uncertainty:	1.14721E-05	Bq/kg FM
relative ext.(Std.-)uncertainty:	11.546	%
Best Bayesian Estimates: <input type="checkbox"/> min. Coverage-Intervall		
Value output quantity:	9.93563E-05	Bq/kg FM
extendend (Std.-)uncertainty:	1.14721E-05	Bq/kg FM
lower range limit:	7.68714E-05	Bq/kg FM
upper range limit:	1.21841E-04	Bq/kg FM

Coverage factor k: 1.0  
Probability (1-gamma): 0.950

**Decision threshold and detection limit for a239 :**

Decision threshold (DT):	1.5483E-05	Bq/kg FM	Iterations: 1
Detection limit (DL):	2.7669E-05	Bq/kg FM	Iterations: 5

k\_alpha=3.000, k\_beta=1.645 Method: ISO 11929:2019, by iteration

**Monte Carlo Simulation:**

Number of simul. measurments	100000	<input type="checkbox"/> Values <0 included
Number of runs:	1	<input type="checkbox"/> min. Coverage interval
relSD%:		
primary estimate:	9.93778E-05	Bq/kg FM 0.037
uncertainty primary estimate:	1.15119E-05	Bq/kg FM 0.224
Value output quantity:	9.93778E-05	Bq/kg FM 0.037
extendend uncertainty:	1.15119E-05	Bq/kg FM 0.224
relative extd.(Std.-)uncertainty:	11.584	%
lower range limit:	7.69825E-05	Bq/kg FM 0.126
upper range limit:	1.22087E-04	Bq/kg FM 0.080
Decision threshold (DT):	1.53944E-05	Bq/kg FM 0.873
Detection limit (DL):	2.75371E-05	Bq/kg FM 0.520

active run: 1 IT: 10 Start MC

The corresponding UncertRadio project file is available on the website of this Procedures Manual.

## 8 Catalogue of the chemicals und equipment

### 8.1 Chemicals

The chemicals used should be of analytically pure quality.

- ammonia solution, NH<sub>3</sub>: 13,4 mol·l<sup>-1</sup>;
- slight ammonia-containing water: distilled water with ammonia solution, pH about 8;
- ammonium oxalate solution: 0,32 mol·l<sup>-1</sup>,  
dissolve 4,6 g (NH<sub>4</sub>)<sub>2</sub>C<sub>2</sub>O<sub>4</sub>·H<sub>2</sub>O in distilled water and fill up with distilled water to 100 ml;

---

— anion exchange resin:	DOWEX 1 x 2, 50 mesh to 100 mesh, chloride form;
— ascorbic acid containing hydrochloric acid:	0,5 mol·l <sup>-1</sup> ascorbic acid in 1 mol·l <sup>-1</sup> HCl, 8,3 ml HCl (12,1 mol·l <sup>-1</sup> ) and 8,81 g ascorbic acid (0,05 mol) filled up with distilled water to 100 ml. <b>Prepare always fresh!</b>
— cleaning agent:	e. g. RBS-50-liquid concentrate;
— hydrochloric acid, HCl:	12,1 mol·l <sup>-1</sup> ;
— hydrochloric acid, HCl:	1 mol·l <sup>-1</sup> , 83 ml HCl (12,1 mol·l <sup>-1</sup> ) filled up with distilled water to 1000 ml;
— hydrochloric acid, HCl:	3 mol·l <sup>-1</sup> , 248 ml HCl (12,1 mol·l <sup>-1</sup> ) filled up with distilled water to 1000 ml;
— hydrochloric acid, HCl:	4 mol·l <sup>-1</sup> , 331 ml HCl (12,1 mol·l <sup>-1</sup> ) filled up with distilled water to 1000 ml;
— hydrochloric acid, HCl:	9 mol·l <sup>-1</sup> , 744 ml HCl (12,1 mol·l <sup>-1</sup> ) filled up with distilled water to 1000 ml;
— hydrofluoric acid, HF:	22,6 mol·l <sup>-1</sup> ;
— mixed solution from hydrochloric/hydrofluoric acid:	0,36 mol·l <sup>-1</sup> HCl in 0,01 mol·l <sup>-1</sup> HF, 7,5 ml HCl (12,1 mol·l <sup>-1</sup> ) and 0,13 ml HF (22,6 mol·l <sup>-1</sup> ) filled up with distilled water to 250 ml;
— nitric acid, HNO <sub>3</sub> :	14,4 mol·l <sup>-1</sup> ;
— nitric acid, HNO <sub>3</sub> :	8 mol·l <sup>-1</sup> , 1108 ml HNO <sub>3</sub> (14,4 mol·l <sup>-1</sup> ) filled up with distilled water to 2000 ml;
— Pu-242 tracer solution:	ca. 200 mBq·ml <sup>-1</sup> in HNO <sub>3</sub> (8 mol·l <sup>-1</sup> );
— quartz wool;	
— sodium nitrite, NaNO <sub>2</sub> ;	
— sodium nitrite solution 1:	7,25 mol·l <sup>-1</sup> , 25 g NaNO <sub>2</sub> filled up with distilled water to 50 ml. <b>Prepare always fresh!</b>

---

- sodium nitrite solution 2: 1,74 mol·l<sup>-1</sup>,  
0,6 g NaNO<sub>2</sub> filled up with distilled water to 5 ml.  
**Prepare always fresh!**
- sulfuric acid, H<sub>2</sub>SO<sub>4</sub>: 18 mol·l<sup>-1</sup>;
- TOPO in cyclohexane: 0,2 mol·l<sup>-1</sup>,  
77,13 g tri-n-octylphosphineoxide (TOPO) filled up  
with cyclohexane to 1000 ml.

## 8.2 Equipment

### 8.2.1 Laboratory equipment

The following equipment is used for the procedure:

- laboratory scales and/ or analytical balance;
- drying oven;
- desiccator;
- magnetic stirrer and heat plate;
- ultrasonic bath;
- sand bath;
- 0,45  $\mu$ m glass fibre filter, adapted to the inner diameter of the glass column used;
- muffle furnace;
- diverse variable volume micropipettes;
- glass beakers (250 ml, 600 ml, 1000 ml);
- centrifuge with beakers made of polyethylene (400 ml);
- separating funnel (250 ml, 1000 ml);
- chromatography columns with reservoir and PTFE-valve (length 10 cm, inner diameter 8 mm) to hold the anion exchange resin;
- crystallizing dish;
- stainless steel plates (diameter 25 mm, V2A-steel, material identifier 1.4301g);
- electrodeposition apparatus (see Figure 1);
- constant current power supply (max. 30 V, 5 A).

### 8.2.2 Apparatus for electrodeposition of plutonium

The electrodeposition apparatus is presented schematically in Figure 1.

A new electrolysis vessel is used for each electrodeposition procedure in order to avoid cross contamination. Stainless steel plates prepared according to Section 8.3.3.2 must be

connected tight fitting to the stainless steel plate and must be connected to the minus-pole of the constant current power supply. The platinum electrode taken out of the nitric acid is rinsed with distilled water and attached in the slit of the electrolysis vessel at a distance of approximately 10 mm to stainless steel plate.

A central borehole of 6 mm allows to remove the preparation to the top of the stainless steel block via pushing a bar through the bottom.

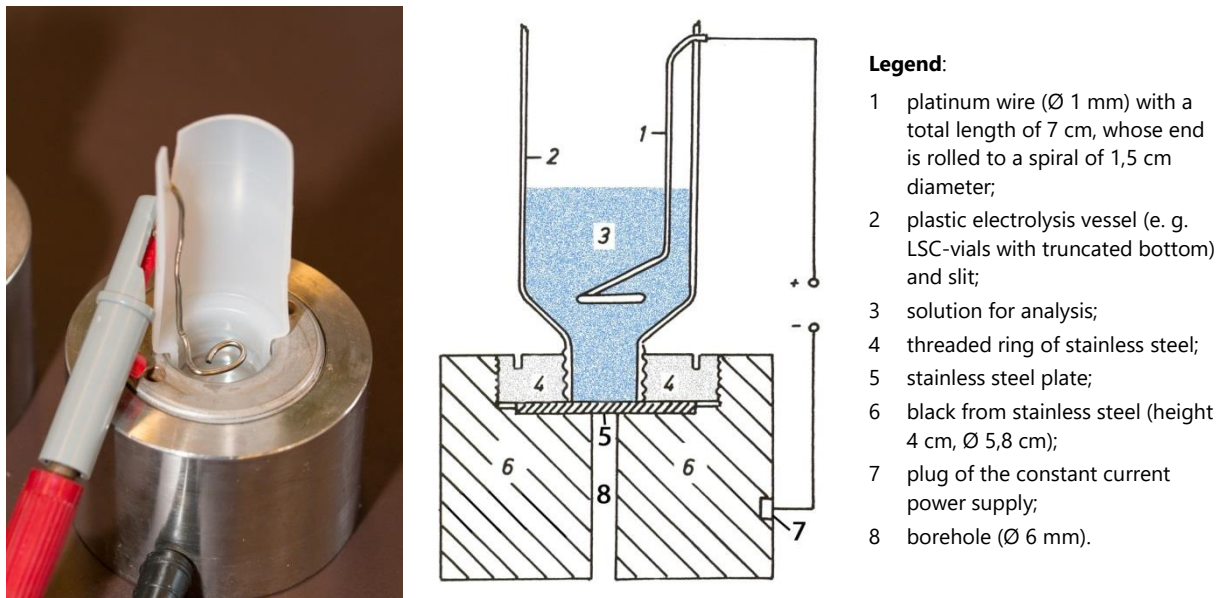

**Fig. 1:** Apparatus for electrochemical deposition of plutonium (not in scale)

The analysis solution is thoroughly mixed via gas formation and process heat during electrodeposition. The plastic electrolysis cell is covered by a suitable single bulb condenser (not included in Figure 1) to reduce losses through evaporation.

### 8.2.3 Measurement devices

- alpha spectrometer with ion-implanted Si-semiconductor detector (300 mm<sup>2</sup> or 450 mm<sup>2</sup>, approx. 20 keV full width at half peak maximum);
- measurement electronics;
- vacuum system;
- evaluation software.

## **8.3 Preliminary works**

### **8.3.1 Preparation of glassware**

All glassware used is placed in 70 °C warm solution of 2 % RBS-50 overnight. Afterwards, they are thoroughly rinsed with tap water, shortly put into hydrochloric acid (1 mol·l<sup>-1</sup>) and thoroughly rinsed with distilled water.

### **8.3.2 Preparation of the anion exchange column**

#### **8.3.2.1 Conversion of the anion exchange resin from chloride into nitrate form**

The DOWEX 1 x 2 anion exchange resin is converted into the nitrate form by placing it in nitric acid (8 mol·l<sup>-1</sup>) for at least 24 hours.

The resin is rinsed two to three times with approx. 1,5 bed volumes of nitric acid (8 mol·l<sup>-1</sup>). The rinsing solution is either sucked up or decanted, depending on the quality of the resin. The prepared resin is stored in 1,5 bed volumes of distilled water.

#### **8.3.2.2 Packing of the anion exchange column**

If only chromatography columns without frit are available, a glass wool plug is inserted into the column. A glass-fibre filter with 0,45  $\mu$ m pore size is placed on its top. The anion exchange resin prepared according to Section 8.3.2.1 is filled to height of 5 cm into the column and is covered by an additional glass-fibre filter.

#### **8.3.2.3 Conditioning of the anion exchange column**

The resin is washed using 50 ml nitric acid (8 mol·l<sup>-1</sup>) at a flow rate of 1 ml per minute.

**Note:**

The anion exchange resin must remain moistened throughout the workflow. The column loaded with resin must not run dry.

### **8.3.3 Preparation of the electrodeposition**

#### **8.3.3.1 Cleaning and operational test of the electrolysis apparatus**

The stainless steel block of the electrolysis apparatus is cleaned as described for glassware in Section 8.3.1.

A cleaning electrodeposition (see Section 3.4) without tracer is frequently carried out for one hour to test the stainless steel block and the platinum electrode for potential. The stainless steel plate is then analysed as control. Is the cleaning electrodeposition carried out as operational test, only, the stainless steel plate may be discarded.

### 8.3.3.2 Preparation of the stainless steel plates

Stainless steel plates are treated with 2 % RBS-50 solution in an ultrasonic bath at 50°C for 5 minutes, first. Afterwards, they are thoroughly cleaned with distilled water and once with ethanol before stored in ethanol. Before use, prepared stainless steel plates are removed out of the storage solution and dried at approximately 70 °C on a hotplate.

## References

- [1] Schüttelkopf, H.: *Bestimmung von Plutonium in Probenmaterialien der Umgebungsüberwachung*. In International Atom Energy Agency, ed: Rapid Methods for Measuring Radioactivity in the Environment (Proc. Int. Symp.), Neuherberg 05. – 09. Juli 1971. Wien: IAEA, 1971, Paper SM-148/61, S. 183 – 197.
- [2] Talvitie, N. A.: *Radiochemical Determination of Plutonium in Environmental and Biological Samples by Ion Exchange*. Anal. Chem., 1971, Vol. 43, S. 1827 – 1830.
- [3] Talvitie, N. A.: *Electrodeposition of Actinides for Alpha Spectrometric Determination*. Anal. Chem., 1972, Vol. 44, S. 280 – 283.
- [4] Frindik, O.: *Alphaspektrometrische Methoden zur Bestimmung von Plutonium und Uran in Lebensmitteln, biologischem Material und Böden*. BFE-Bericht 1980/6. Karlsruhe: Bundesforschungsinstitut für Ernährung und Lebensmittel, 1980.
- [5] Puphal, K. W., Olsen, D. R.: *Electrodeposition of Alpha-Emitting Nuclides from a Mixed Oxalate-Chloride Electrolyte*. Anal. Chem., 1972, Vol. 44, S. 284 – 289.
- [6] Holm, E.: *Review of Alpha-Particle Spectrometric Measurements of Actinides*. Int. J. Appl. Radiat. Isot., 1984, Vol. 35, S. 285 – 290.
- [7] ISO 11929-1:2019 *Determination of the characteristic limits (decision threshold, detection limit and limits of the coverage interval) for measurements of ionizing radiation — Fundamentals and application — Part 1: Elementary applications*.
- [8] Kanisch, G.: *Aspekte der quantitativen Aktivitätsbestimmung mit der Low-Level-Alpha-Spektrometrie: Peakanpassung, Aktivitätsberechnung mit Unsicherheiten Budget und Nachweisgrenzen*. In Bundesministerium für Umwelt, Naturschutz und Reaktorsicherheit, ed.: 12. Fachgespräch zur Überwachung der Umweltradioaktivität, Bonn, 08. – 10. April 2003. Bonn: BMU, 2003, S. 37 - 44.
- [9] Kanisch, G.: *UncertRadio: Ein Programm zur Ermittlung von Unsicherheit, Unsicherheitsbudget und Nachweisgrenzen einer Ergebnisgröße*. In Bundesministerium für Umwelt, Naturschutz, Bau und Reaktorsicherheit, ed.: 14. Fachgespräch zur Überwachung der Umweltradioaktivität, Freiburg, 24. – 26. März 2009 [online]. Bonn: BMU, 2010, S. 87 – 95. ISSN 1869-585X. Available at: <http://www.bmu.de/WS2948/> [last accessed on 13 November 2020].